

Asymmetrisch offen, bis 10 m³

A 5,5

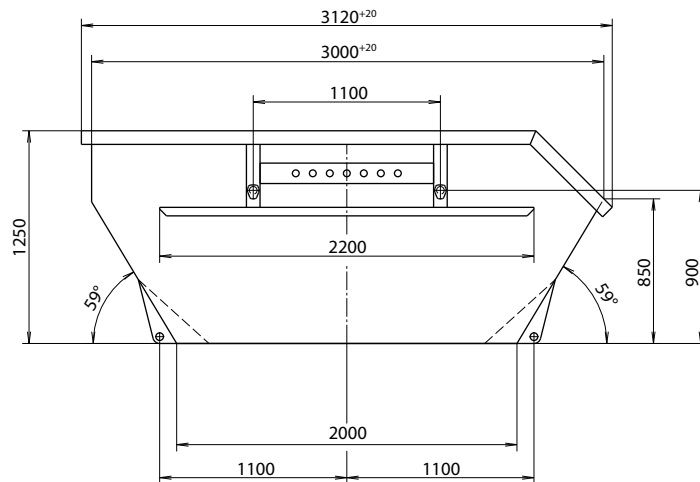

A 7

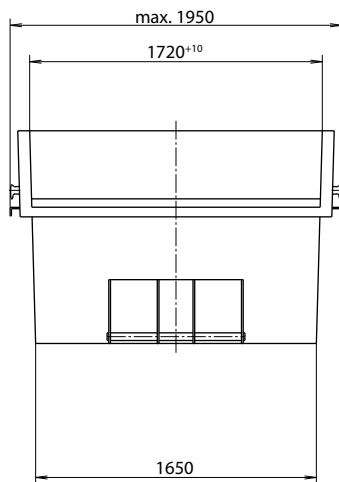
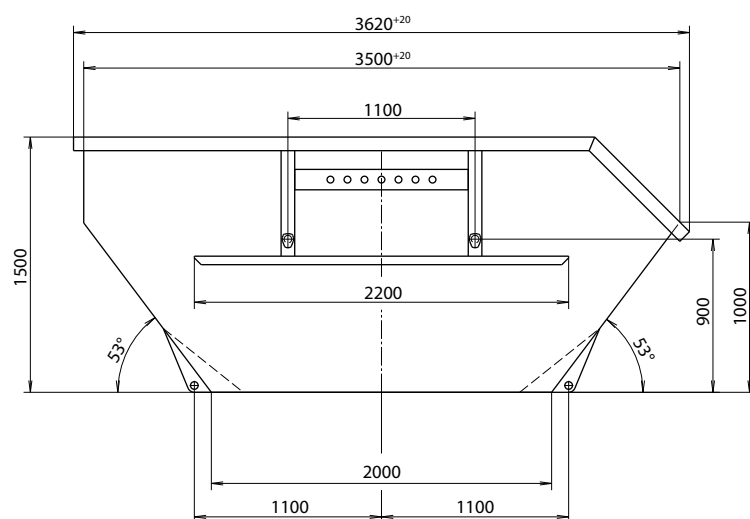
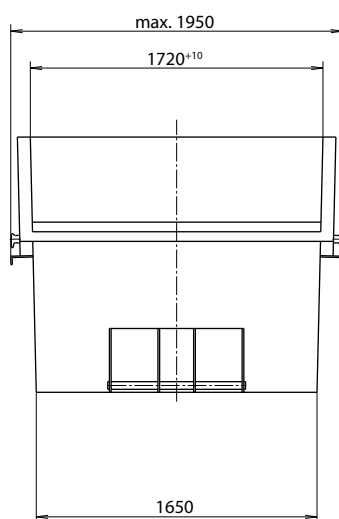

A 10

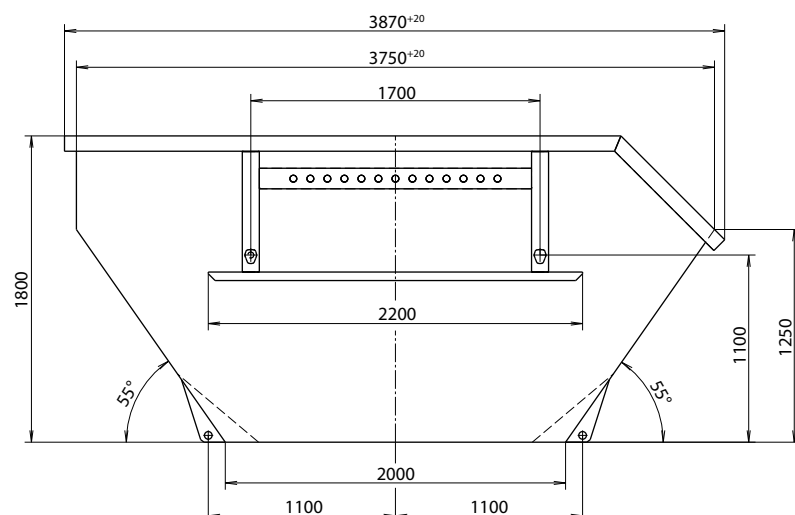
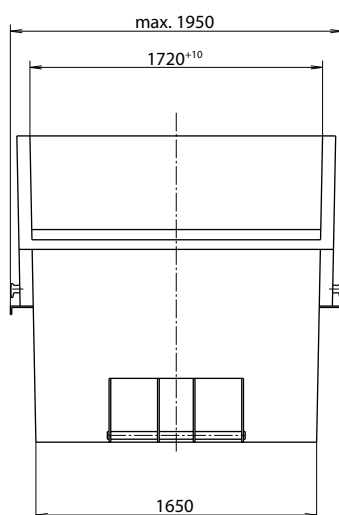

Symmetrisch offen, bis 10 m³

S 5,5

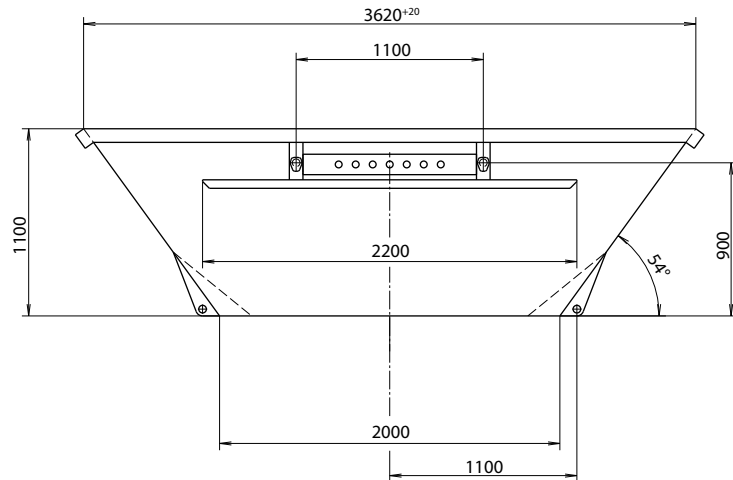
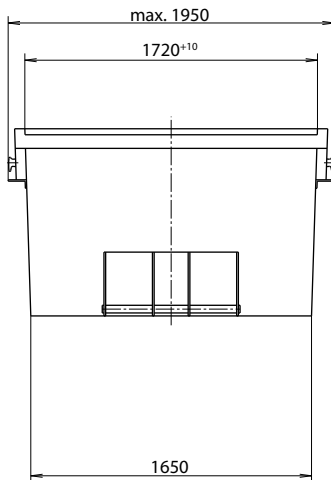

S 7

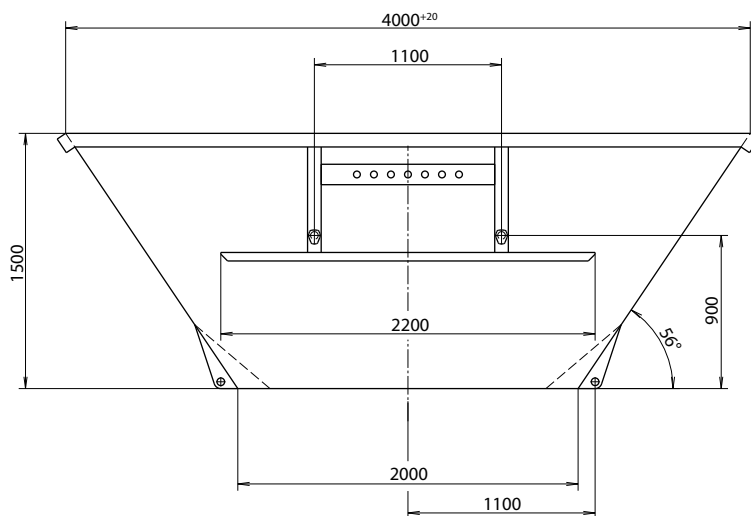
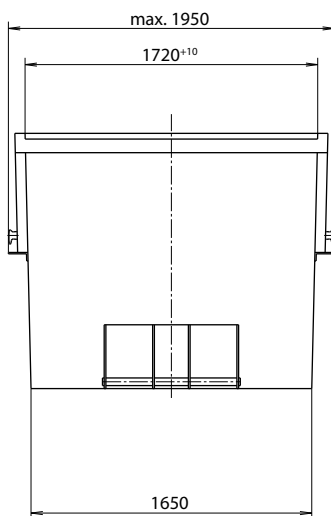

S 10

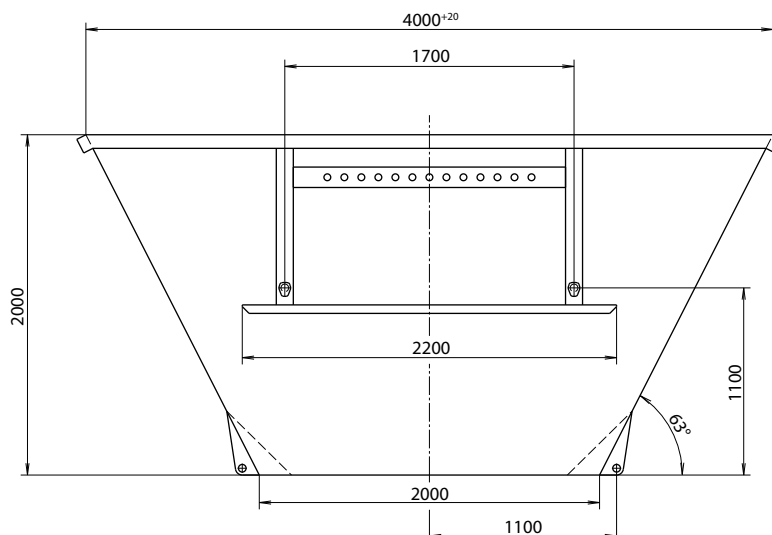
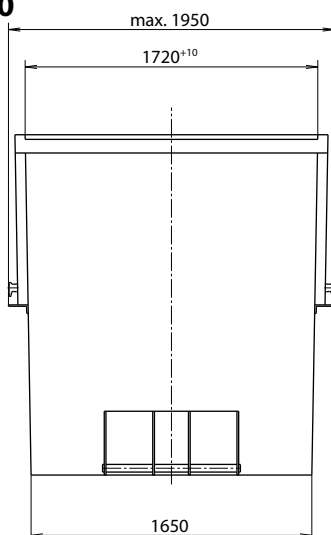

Symmetrisch gedeckt, bis 10 m³

SD 5,5

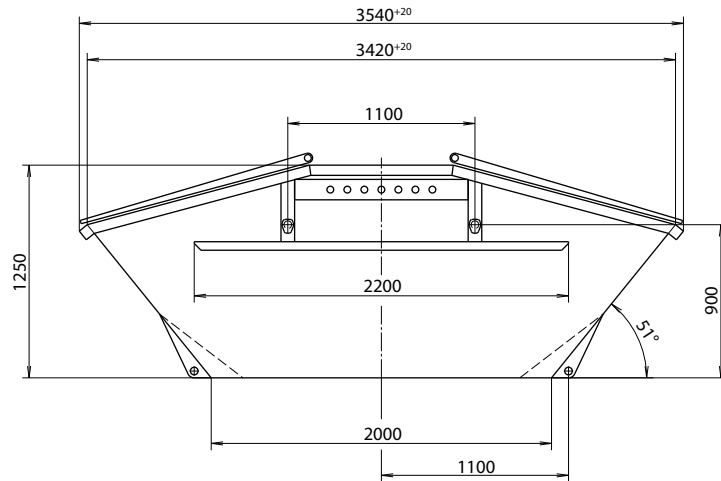
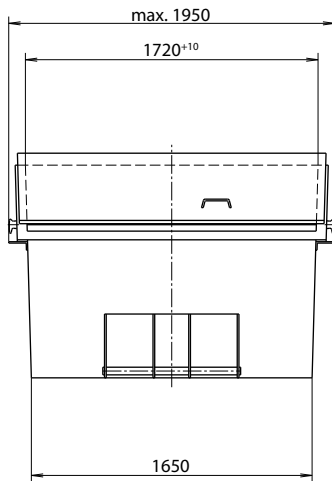

SD 7

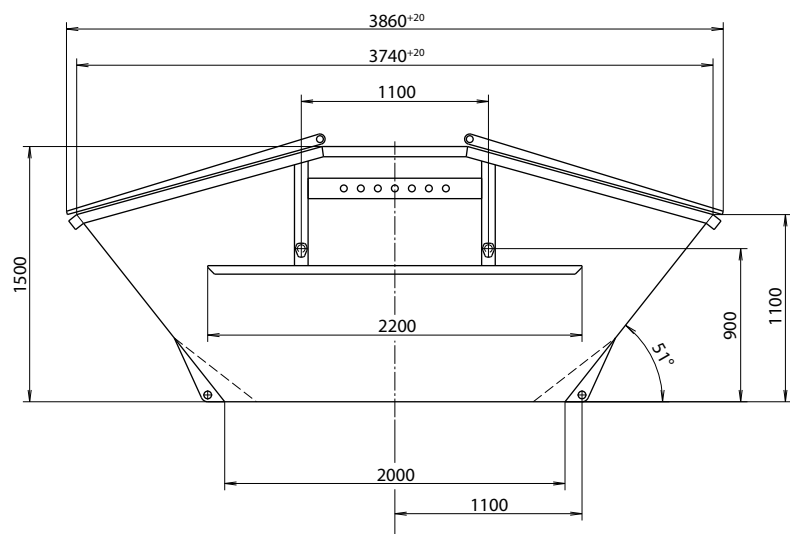
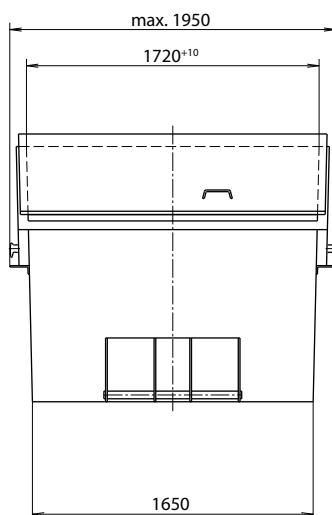

SD 10

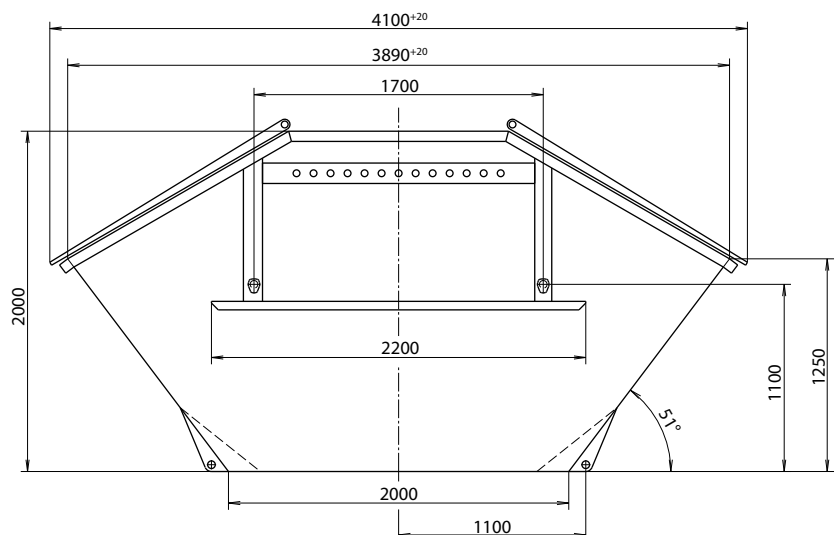
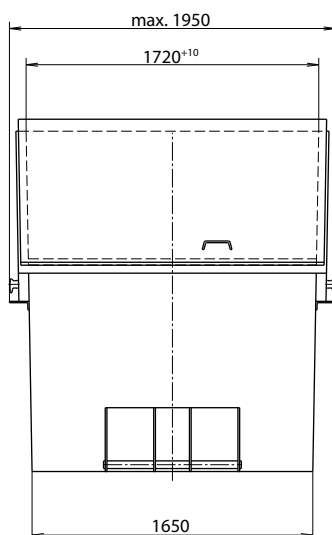

Asymmetrisch offen, bis 20 m³

A 15

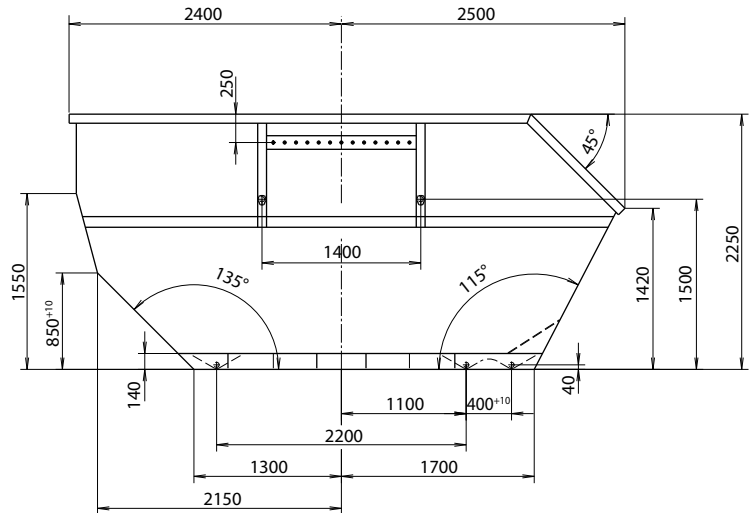
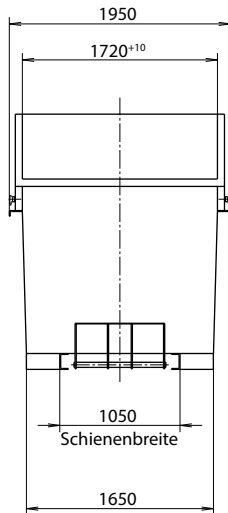

A 20

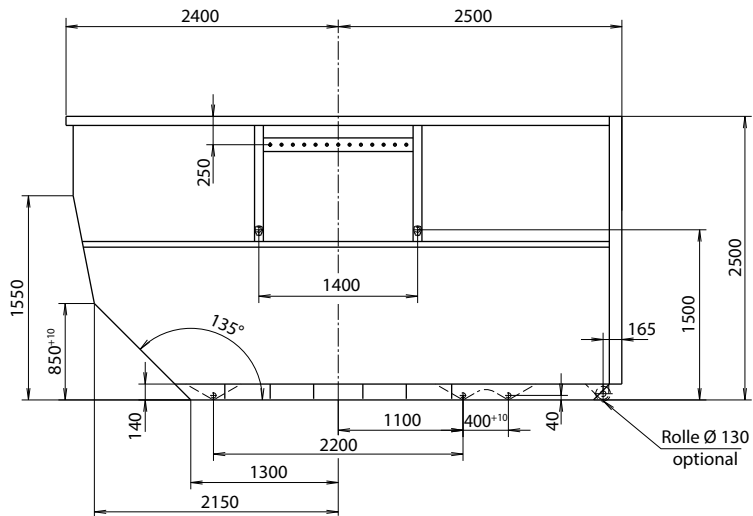
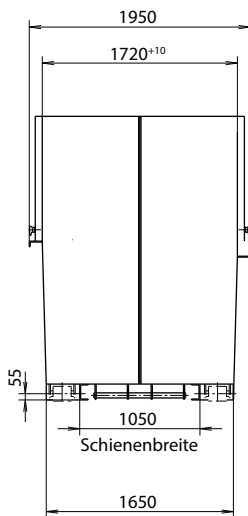

Mobile Abfallpresse nach DIN 30 730-MAP-AKF

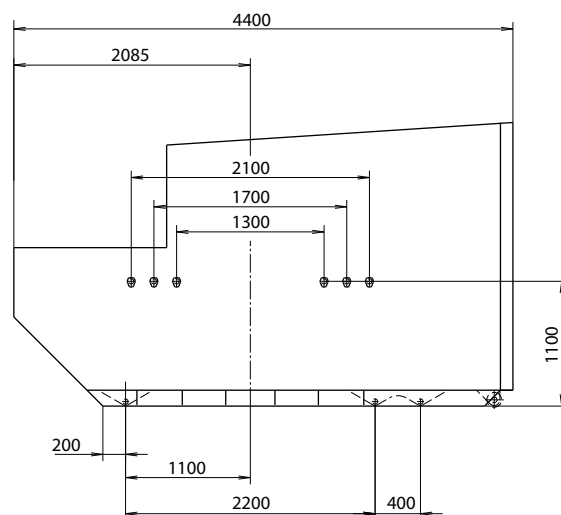
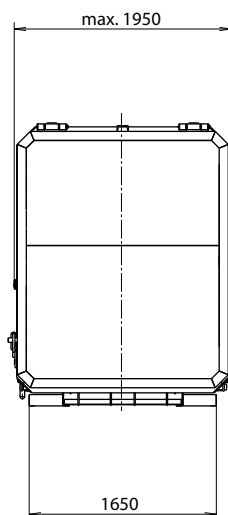

Kipplager

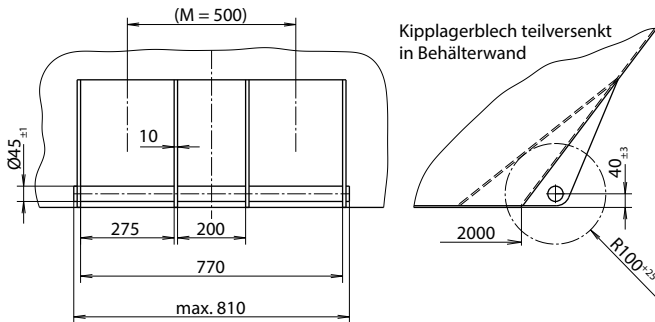

Aufhängezapfen

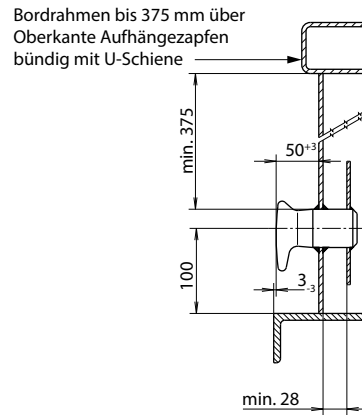

Verzurrleiste

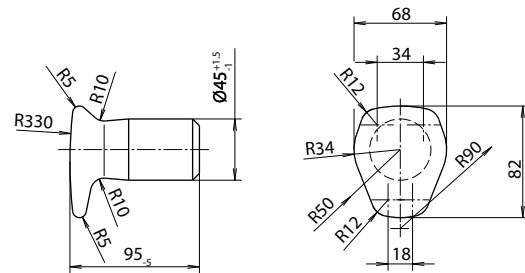
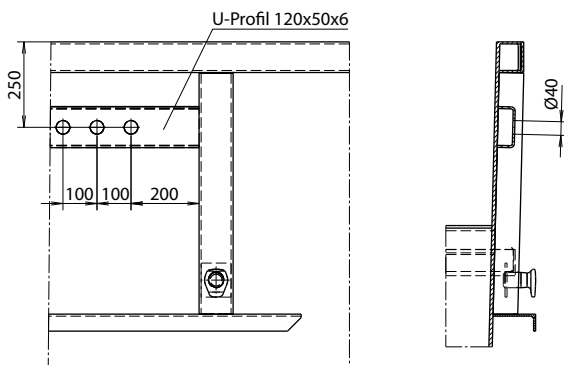

Unterrahmen-Prinzipskizze (DIN 30 720 Teil 2)

