

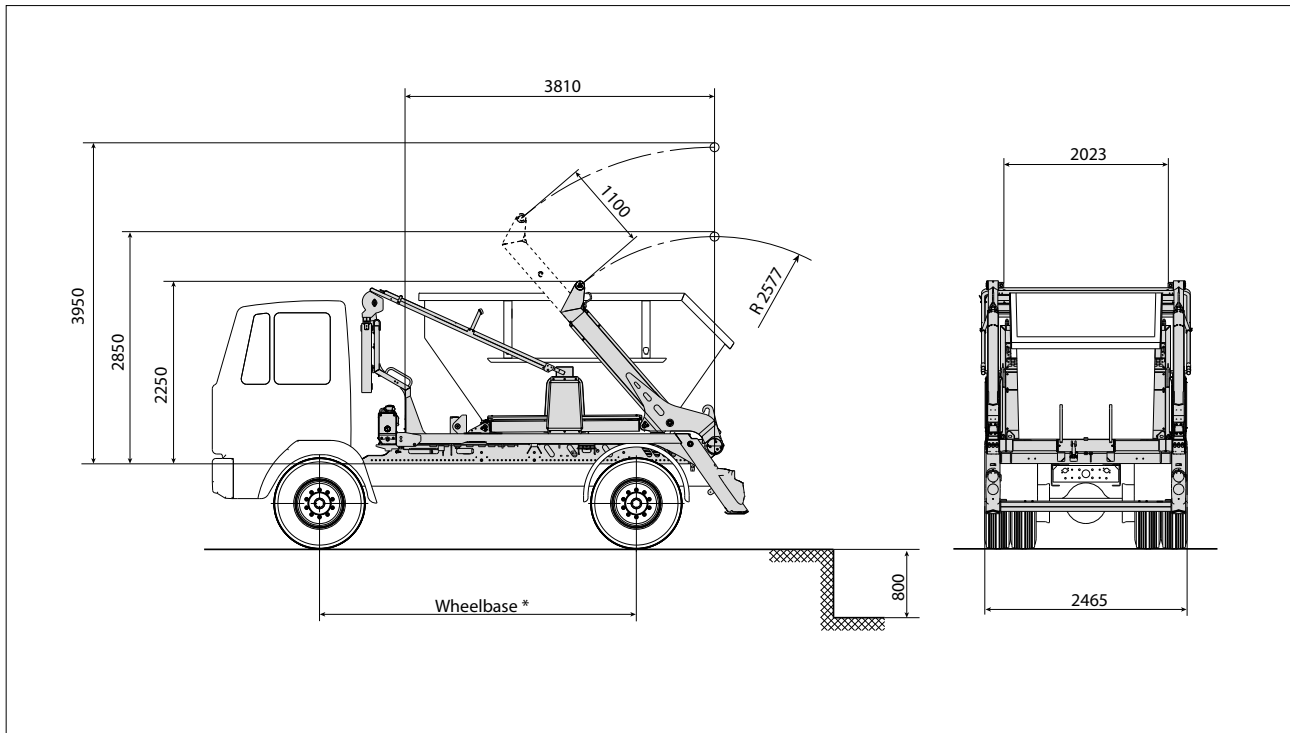

Skip loader SL10-MT



Technical data

Loads and weights:

Lifting load from carriageway level ** (boom length 2,577 mm)	max. 11,000 kg
Lifting load from carriageway level ** (boom length 3,677 mm)	max. 7,000 kg
Lifting load from underfloor level (boom length 2,577 mm)	max. 7,500 kg
Lifting load from underfloor level (boom length 3,677 mm)	max. 5,300 kg
Weight of the skip handler (standard version, pre-assembled)	approx. 2,620 kg
Underfloor position	800 mm

Hydraulic system:

Max. operating pressure	300 bar
Oil tank capacity	26 l
Capacity of the entire hydraulic system	approx. 110 l

Suitable chassis:

Permissible total weight	12,000 – 15,000 kg
Wheelbase	approx. 3,300 – 3,600 mm
Frame overhang	1,000 – 1,150 mm

Exact dimensions and weights are defined upon determination of the chassis.

Suitable container sizes:

- Container according to C.H.E.M. TS 14 up to 9 m³,
- Container according to C.H.E.M. TS 14 up to 12 m³,
- Compacted waste container according to C.H.E.M. TS 2 up to 10 m³
- Special containers by arrangement.

** without consideration of stability.

Subject to change in the course of further development!