



Skip Loader

Innovative and efficient in every detail

| meiller.com

| boweld.co.uk

The MEILLER company

Innovation from tradition for 170 years

About MEILLER

The Munich-based, family-run company, which has been established in 1850, can look back on a long tradition. From the very first, MEILLER has aimed at producing innovative, high-quality products with great customer's benefits both for the building and waste management industry. The product portfolio, consisting of rear tippers, three-way tippers and tipping semi-trailers for the building sector as well as hooklifts and skip loaders for the waste management sector, has been complemented and advanced systematically during the past years. MEILLER is the market leader in Germany and has a market share of more than 70 % in skip loaders.

Customers can obtain steel constructions, hydraulic systems and control electronics from a single provider. The unique compatibility of components demonstrates the efficiency and operational reliability of MEILLER products. They are created in four MEILLER plants in Europe.

Their quality bears a single name: MEILLER.



About BOWELD

BOWELD Truck Bodies Ltd is a 100 % subsidiary of MEILLER Fahrzeug- und Maschinenfabrik GmbH & Co KG.

Established over 25 years ago, BOWELD specialized in the design and manufacture of steel tipping bodies and auxiliary equipment.

The company manufactures the most technically advanced, design registered, steel tipping bodies available in the UK with individual products enjoying the benefit of a number of extensive patents. Product quality is second to none and is monitored throughout the manufacturing process by a QA system, ISO 9001:2015, specially developed for the manufacture of tipping bodies.





Skip Loader

Innovative and efficient in every detail

The MEILLER skip loader programme combines innovative solutions with a modern design. It is designed for daily and rugged operation.

Transport high payloads fast and safely thanks to the low tare weight of the skiploader equipment. Container handling has been designed for ease of use and practicality.

MEILLER skip loaders are designed for ultimate productivity – from the very first day and over their entire operating life.

MEILLER stands for ultimate product quality and value retention.

Ultimate quality through intelligent detailed solutions

MEILLER skip loaders are economical and durable. Build quality originates in state of the art processing methods and benefits from use of high strength materials. This means the skip Loader is extremely strong and well protected against corrosion.

The loading platform of the MEILLER skip loader comes without a vehicle-specific subframe. This results in a low tare weight and permits high payloads.

The high-quality MEILLER hydraulics ensure work operations are fast and precise. This is complemented by precise and load-independent synchronisation of stabilising jacks and telescoping lifting arms, with very low operational noise.



The MEILLER skip loader programme: from the general purpose single product right up to the customised system solution, here the SL14

Skip Loaders

Innovative and efficient in every detail

MEILLER, the competent system supplier

MEILLER skip loaders are ideal for the entire range of chassis produced by all vehicle manufacturers.

We work closely together with truck manufacturers and optimally match MEILLER products to the chassis. The MEILLER loading platform is designed to be vehicle-neutral. We adapt your required product quickly and problem-free to every chassis.

Close collaboration with vehicle manufacturers results in short response times to new market demands.

Designed for practical use.

With MEILLER skip loaders you transport skips and containers efficiently and reliably. They stand the test in the construction and waste management sectors and are made for harsh conditions.

- MEILLER skip loaders are strong and easy maintained.
- The loading platform is easily accessible via steps.
- All work operations are simple and safe.
- When you have service needs your mobile MEILLER customer service will quickly and reliably assist you.

Made for rugged use in the construction and waste management sectors: the MEILLER skip loader.



Your benefits

- **Economic operation through high reliability**
- **High working speed through easy controls and intelligent hydraulics**
- **Safe operation and transportation through certified solutions**
- **High payloads with low tare weight**
- **Maintenance-friendly and value maintained through high product quality**

TECHNICAL DATA

Lifting forces	from 7 t to 17 t from road surface
for truck chassis	from 9 t to 33 t total weight
for containers/skips	DIN 30 735 DIN 30 720 Part 1 and 2 DIN 30 730-MAP-AKF Silo container (further containers on request)

Skip Loader SL14

Technical details

SL14-MTG

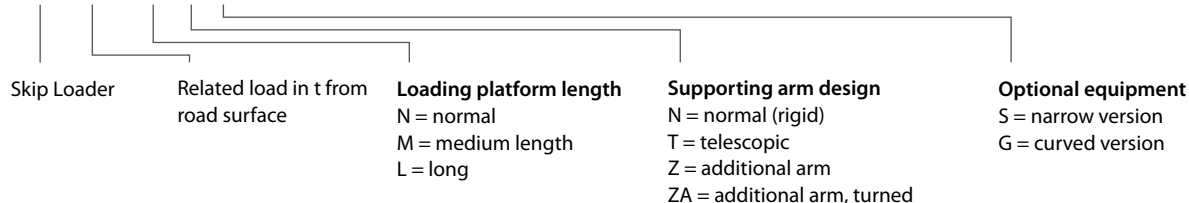

TECHNICAL DATA

Max. lifting force
 from road surface: 14,000 kg
 SL weight: 2,770 – 3,010 kg

SUITABLE CHASSIS

up to 20 t

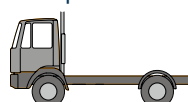

CONTAINER SIZES

DIN 30 720 Part 1

DIN 30 720 Part 2

DIN 30 730-MAP-AKF

DIN 30 730-MAP-AKF

silos container *)



SUPPORTING ARM TYPES

N lifting arm

T lifting arm

TG lifting arm

Z lifting arm

ZA lifting arm

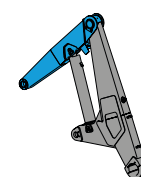
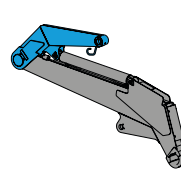
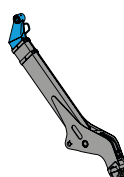
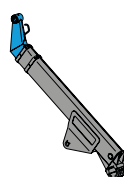
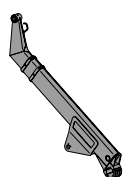

Z lifting arm

- for low height in travel position (e.g. journeys through underpasses)

ZA lifting arm

- for low height in working position (e.g. picking up skips in halls)

*) with appropriate additional equipment

MEILLER Skip Loader SL14

UK specific details

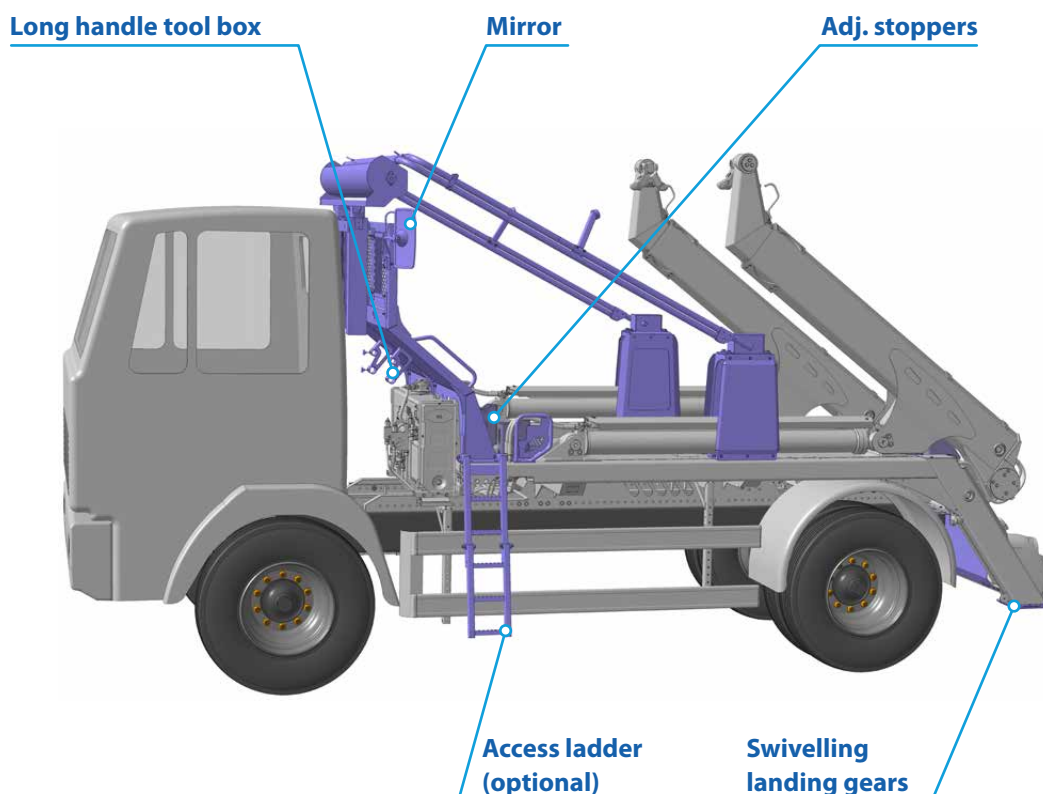
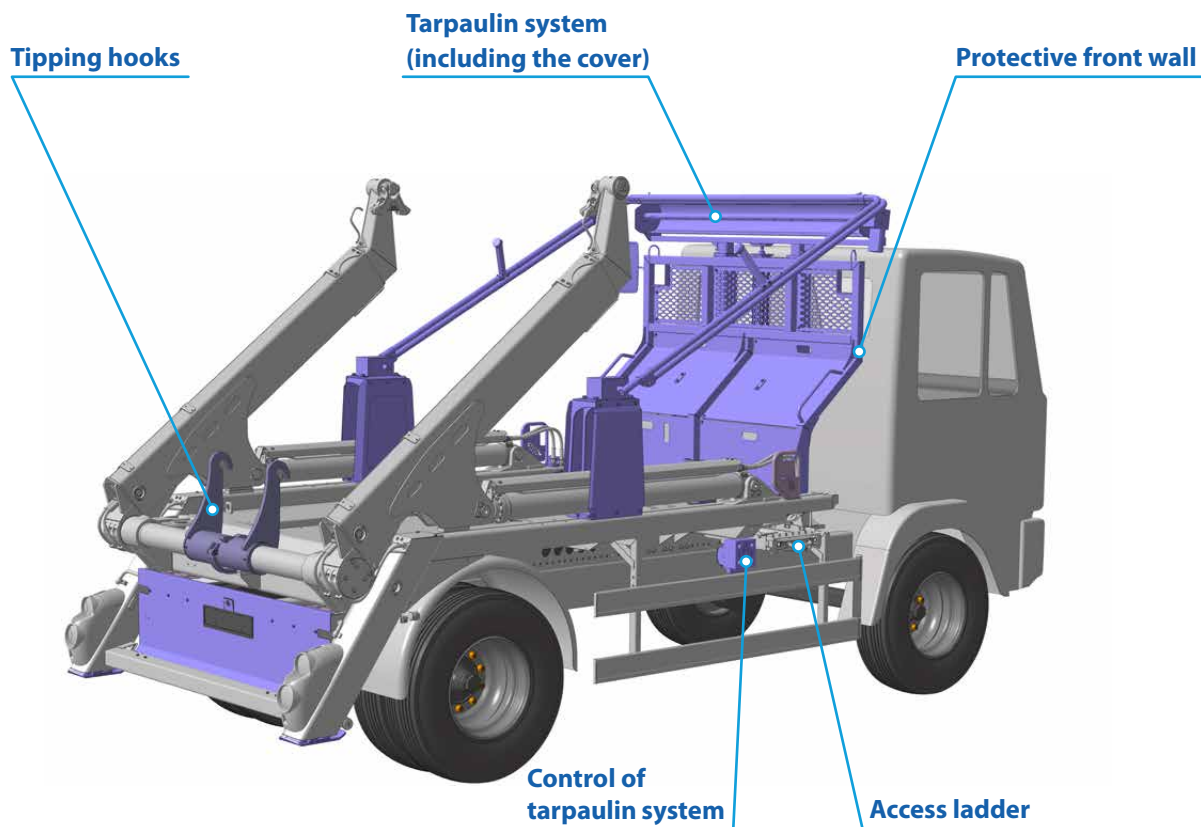

Original MEILLER hydraulic system



The original MEILLER hydraulic system is the key component of all MEILLER products.

Developed and produced in Munich according to the highest quality standards, every single component powers our tippers to a high level performance – even under the most extreme conditions.



Your benefits

- **Minimum tare weight for best payloads**
- **High-strength materials and nitrided surfaces for a long lifetime**
- **Practically maintenance-free, for example by dirt-resistant components**

Powerful

You always have more onboard power with the MEILLER hydraulic system. Our high pressure hydraulic system is made of extremely high grade sturdy material and ensures minimum tare weight and best payload with optimal cylinder sizes.

Durable

Our hydraulic system has a long lifetime. High-strength materials, nitrided surfaces and the metallic guide make the system wear-free and dirt-resistant.

Efficient

Efficient working is standard with the MEILLER hydraulic system. MEILLER control valves and pumps give best cycle times and optimally designed oil circuits. The system is practically maintenance-free.



Our hydraulic system works with high pressure up to 320 bar. The short tipping and lowering times are achieved by the high energy density. Thanks to high-strength materials and a low oil volume our hydraulic system achieves the highest payloads.

Operation

Simple and convenient for ultimate work safety

Operation of MEILLER skip loaders is easy and safe: all functions are logical, easy to understand and simple to use. It is even more convenient with the i.s.a.r. remote control: load containers from a safe distance and at a location that gives you the best visibility. With the preprogrammed sequence control processes it is easy to operate at the press of a button.

Every MEILLER skip loader is serially equipped with the i.s.a.r. remote control.

Always control your sequences fast and safely with the practical i.s.a.r. remote control



One button – many processes: very easy with sequence control

With the preprogrammed processes of the i.s.a.r. radio control unit you save time and avoid mistakes in the sequence of operating steps. Up to 30 seconds can be saved for each sequence. You start a complete process as easy as this: press button „D“, choose program sequence and move the

Joystick to the right. You activate a defined sequence of functions that are executed after each other. You always have full control and can intervene in the sequences at any time. With the Joystick you regulate the speed.



Three different programme sequences are available:

1. Unlock container:

fold down all tipping hooks, unlock the clamping mechanism and locking mechanism (if fitted)

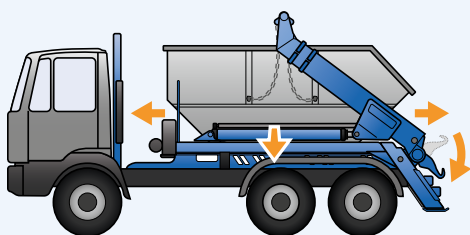

Unlocking a container

2. Put down container:

extend props, fold down all tipping hooks, unlock the container, swivel out the main arm

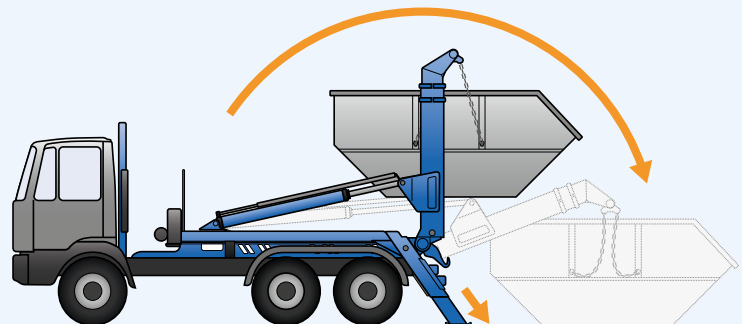

Putting down a container ...

i.s.a.r. remote control

- One radio control unit for all functions
- Independent operating position, operator can take the best position
- Long radio range
- For rugged use:
 - › Can also be operated with gloves & Illuminated buttons for night operation
 - › Integrated antenna & Rubber surround
- Simple container handling:
 - › Control elements arranged logically and clearly
 - › Easy operation with joystick & One-hand operation possible
- Low weight of only approx. 340 g
- Optimised power supply (Li-Ion battery without memory effect)
- Engine Start/Stop button centrally positioned
- Emergency stop button
- Belt clip and magnetic holder to prevent loss

Your benefits

- **Easy to understand radio control unit for all functions.**
- **Handling designed for rugged day and night use, can also be operated with gloves**
- **Sequence control for program mode ensures high work safety**
- **Control energy-efficient and time-saving**
- **Sophisticated and logical operating concept**
- **Sensitive control for optimum sequences**

3. Unlock container and make ready to travel:

retract the telescope, lock the clamping mechanism as well as the hook in the rear. All tipping hooks are folded up, finally the stabilising jacks are retracted – the driver can be confident that his skip loader is ready for driving on roads.

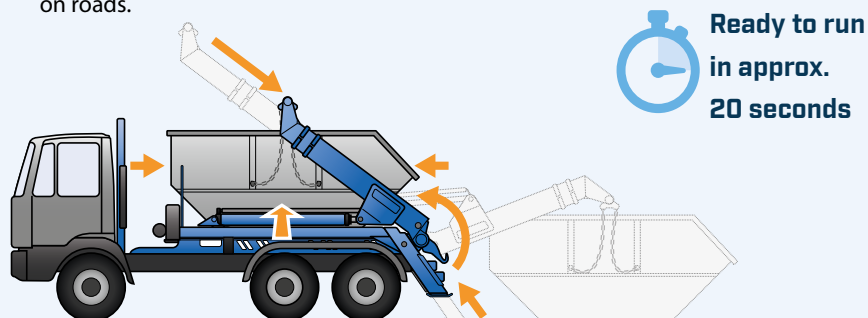

... lock and make ready to travel.

Tarpaulin system for Skip Loaders

Innovative and efficient in every detail

Load securing – an all-round solution from MEILLER.

The securing of the load in the skip is as essential as the securing of the skip itself on the skip loader. The tarpaulin system for MEILLER skip loaders is the perfect solution for a safe and efficient operation which allows you to secure your load in the skip in accordance with the legal regulations as well as in a simple and practice-oriented way.

Everything from a single source

The tarpaulin system matches perfectly with the MEILLER skip loader, allowing the customer to benefit from an integrated solution from one source.

Your benefits

- **Safe and convenient working**
– no potential danger for the driver when securing the load
- **Secure transport due to covered load**
- **High working speed**
- **Simple operation**
- **Automatically working system**

SHEETING SYSTEM "V-COVER"

Body type	Max. covered container size				
	10 m ³ symetric (DIN 30 720-1)	10 m ³ asymeric (DIN 30 720-1)	15 m ³ (DIN 30 720-2)	20 m ³ (DIN 30 720-2)	Special containers
SL10-M	◆	◆	–	–	–
SL14-M	◆	◆	–	–	◇
SL14-L	◆	◆	–	–	◇
SL16-N	◆	◆	–	–	◇
SL16-M	◆	◆	◆	–	◇

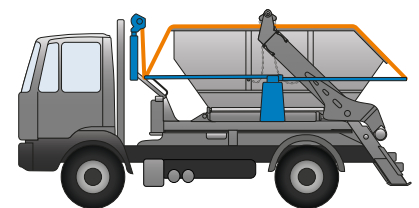

Secure ... quick ... economical.

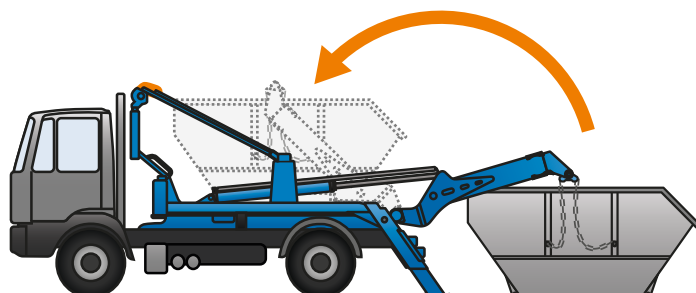

1. The skip is picked up and secured on the loading area.

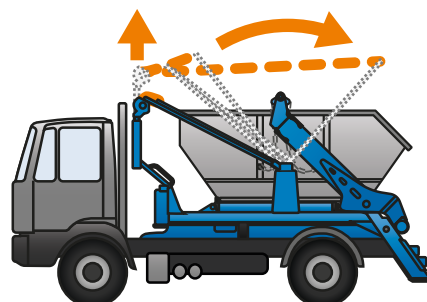

2. The tarpaulin reel with drive motor is lifted from the height-adjustable tower behind the cab.



Tarpaulin programme for skip loader

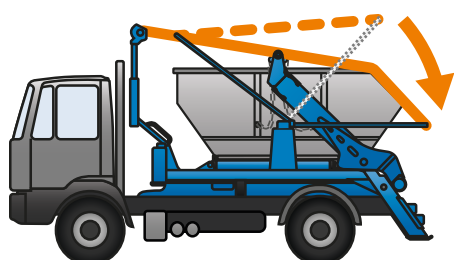

3. The lifting rods at the rear guide the tarpaulin safely over the entire skip and secure it downwards.

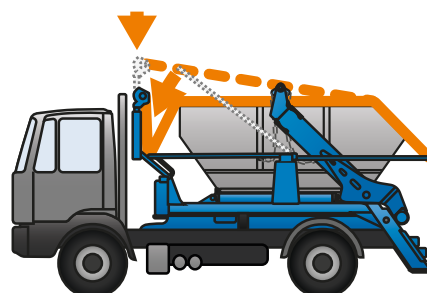

4. The tensioning rods at the front pull the tarpaulin downwards and secure it against airstream.



Features for practical use

Practical solutions for everyday, rugged operation

Economic ...

MEILLER protects you against risks, because our products remain economic over their entire operating life:

- Low maintenance requirements saves costs for spare parts and repairs.
- MEILLER product quality ensures good value retention and ensures high residual values.
- Reliable MEILLER after-sales service and high spare-parts availability minimise down times.

Adapt the chain length - easy and practical

Adapt your chain length with the MEILLER fastener: the practical chain suspension device at the top end of the telescopic arms makes it easy to shorten or lengthen the chain.



Optimum chain handling with the patented MEILLER M fastener.

MEILLER skip loaders guarantee safe operation thanks to many sophisticated optional extras:

- LED rear lighting: you profit from additional road safety
- Camera systems: provide the best all-round view in the working area
- Overload controller: detects possible vehicle overloading. Overload protection reduces vehicle wear and tear and provides road safety
- Automatic level compensation
- Exact synchronisation of the rear prop gives high stability
- Underride protection: quickly removed for repairs
- Practical emergency control

Robust control unit:

MEILLER skip loaders have a practical control unit with emergency controller and protected mounting of all controller components.



MEILLER control unit with integrated overload control display (standard with telescope equipment)

... fast.

Intelligent MEILLER features increase the working speed:

- Load-dependent fast offload: accelerates putting down and tipping, and preserves the hydraulics. Operates over the entire stroke with empty containers.
- Quick movement is only switched on in a specific uncritical range for loaded containers
- i.s.a.r.-control radio control unit: work quickly with the radio control unit. With the preprogrammed sequence control processes you save time.
- Powerful MEILLER hydraulics ensure a high working speed.



Tip in
approx. 15
seconds

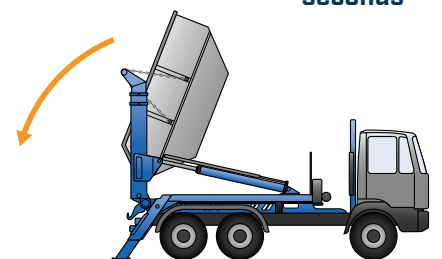

Attachment parts & accessories



Extend as you want – the ideal vehicle for everyone

Optimise your MEILLER skip loader for your own purposes. With our accessories you design your daily work routine to be very safe and practical. The programme ranges from steps over storage options right up to camera systems.

Lots of space for work aids and tools:

- Large storage box behind the cab, also suitable for bulky tools (shovels and brushes), with lockable lid.
- Storage boxes for small parts in the rear, with lockable lid
- Side toolbox
- Side extendible net boxes



Large storage box with lockable lid, fitted transverse behind the onboard frame.



Standard BG-compliant steps.

Climb onto the vehicle quickly and safely:

- Optional: additional side steps on the left side of the skip loader

Your benefits:

- **Minimum tare weight for best payloads**
- **High-strength materials and nitrated surfaces for a long lifetime**
- **Practically maintenance-free, for example by dirt-resistant components**



Room used optimally: toolbox between the axles.

Lights with LED technology

Profit from additional road safety and improved visibility with MEILLER lights equipped with LED technology. A striking design is combined with a long service life and high efficiency. You also save time and costs as LED lights have a longer life.

The MEILLER lights:

- LED rear lighting
- LED floodlight lamps
- LED warning around lamps
- Side MEILLER marker lamps



Container lock

Transport and load skips safely and professionally

MEILLER provides you with a choice of container locks: the modular concept makes different combinations possible. All MEILLER load securing modules are certified and can be operated with the radio control unit. With MEILLER skip loaders you can count on a reliable and appropriate container lock.

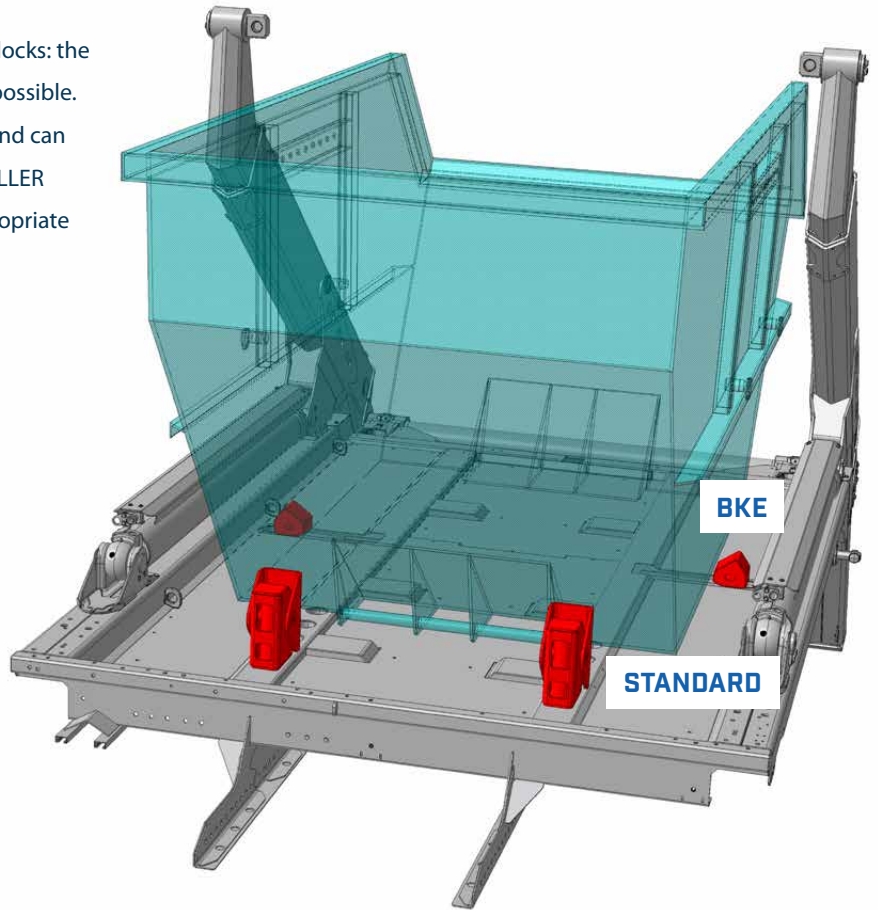

Container lock modules

Choose from the different load securing modules. The combination of the BKE and CV modules gives ultimate safety: that is perfect load securing at the press of a button.



Standard

Skid limit stops manually adjustable



BKE = skip clamping mechanism

Hydraulically operating skid limit stops that secure sides of skips against slipping.

CONTAINER LOCK VARIANTS

	Standard	BKE module
Side	manual	BKE
Front	manual	manual
At the back	skip support	skip support

Your benefits

- Certified and patented solutions.
- Fast and efficient securing through powerful hydraulics
- The right solution for everyone: load securing modules combinable
- Fast and easy to operate with radio control unit



MEILLER Service

Spare parts

Minimise down times through high availability and reliable delivery of spare parts. Our sophisticated logistics will supply you with original parts quickly to wherever they are needed.

Place your trust in the traditional quality of original MEILLER spare parts matched optimally to your MEILLER product.



Urgently needed original MEILLER spare parts come quickly to wherever they are needed.

Product quality

MEILLER places special value on exemplary product quality and excellent value retention. This is why all components are designed for harsh operating conditions and a long service life. They excel through their good processing, reliability and low wear and tear.



To this day, many technical milestones and innovations from MEILLER continue to shape the sectors of construction, waste management and the commercial vehicle industry all over the world.



Every MEILLER employee stands for the high quality of all MEILLER products.



Fast service

Benefit from the expertise and competence of our experienced team. Our mobile after-sales service as well as our worldwide customer service points respond to you quickly whenever you require service.

Be assured, you're in good hands.

MEILLER global network

Full service from a single source



Present worldwide

- MEILLER production sites / sales offices
- Service centers

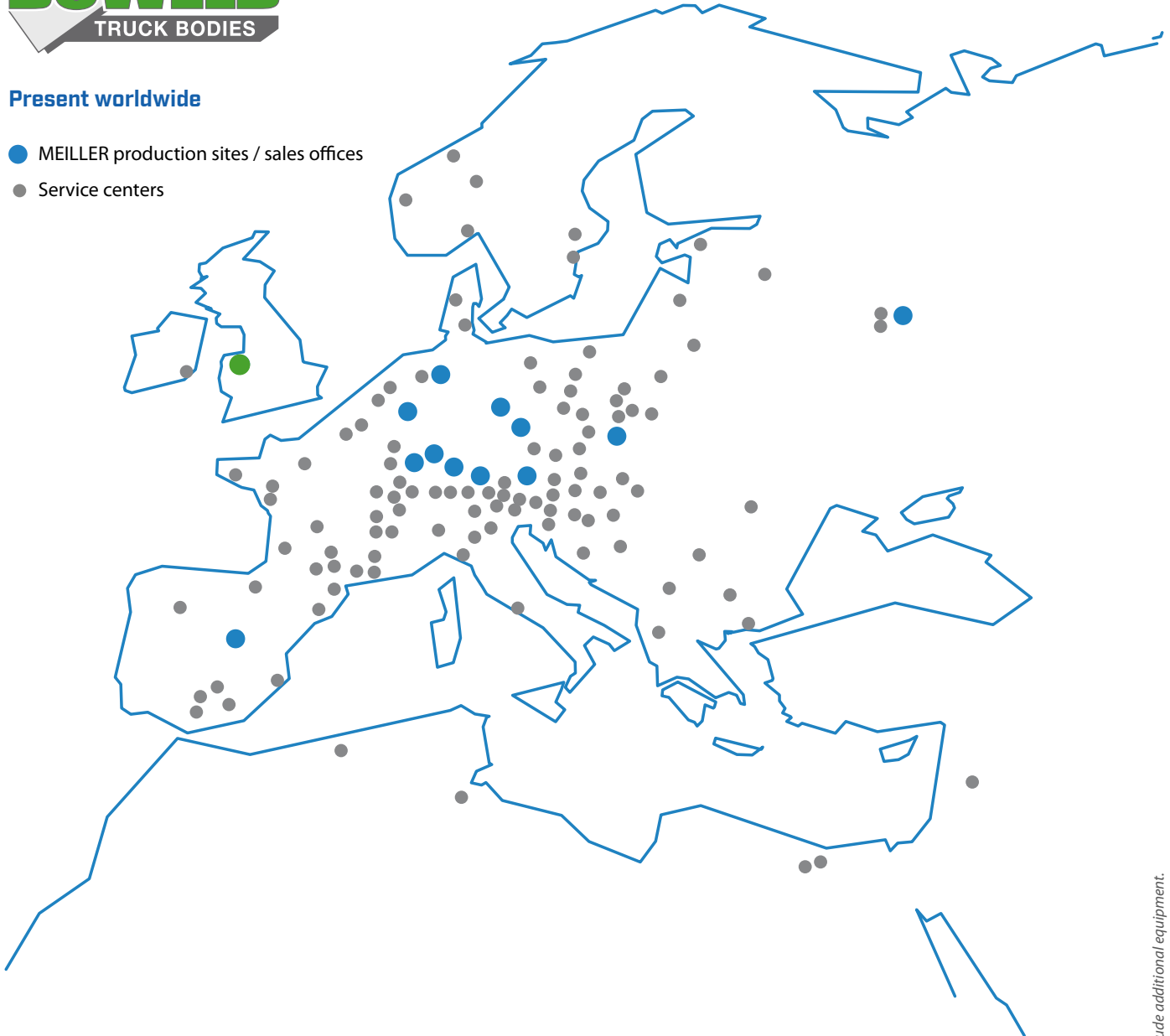

There is a MEILLER production site / sales office near you.

Find the service centers closest to you by searching online at

meiller.com/en/service

www.boweld.co.uk

Boweld Truck Bodies

Pentre Halkyn
Nr. Holywell
Flintshire
CH8 8JP

T: +44 (0) 1352 781566

F: +44 (0) 1352 781141

1753_En-731-0921
Picture similar, can include additional equipment.

F.X. MEILLER

Fahrzeug- und Maschinenfabrik - GmbH & Co KG · Ambossstraße 4 · 80997 Munich, Germany
Telefon: +49 (89) 1487 - 0 · Telefax: +49 (89) 1487-1355 / 1595 · info@meiller.com · www.meiller.com